

Cleaning

Your product has a high quality finish and should be treated with care to preserve the visible surfaces.

Never use abrasives or abrasive cleaning agents to clean this product. Clean regularly with contamination free warm soapy water and a damp soft cloth. Do not use products containing chlorine bleach or hydrochloric acid as these can damage the product. Always rinse the product thoroughly after cleaning to remove cleaning products that can damage the shower.

Warranty Info

Your product comes with a 5 year guarantee, This includes 2 years parts and labor followed by a further 3 years parts only, subject to the following:

Please retain installation & maintenance guide for future reference.

Proof of purchase will be required

The guarantee does not cover faults or damage caused by incorrect installation and/or maintenance, ordinary wear and tear, water composition etc. including:

supply pipes reversed, incorrect pressure or temperature, incorrect use, foreign bodies and/or scale due to the water composition, incorrect cleaning.

We have a policy of continuous improvement and reserve the right to change specifications without notice.

METHVEN UK LIMITED
METHVEN EXPERIENCE CENTRE
3/3A STONE CROSS COURT
YEW TREE WAY
GOLBORNE
WARRINGTON
WA3 3JD
UNITED KINGDOM

INST-AVTBSMNK, AVTBSMWMB0,
AVTBSMEF, AVTBSMEFLF
10.10.2023

TEL: 0800 195 1602
FAX: +44 (0) 1942 680 190
E: sales@uk.methven.com
www.methven.com

Avoca

Thermostatic Bath Shower Mixer

AVTBSMNK, AVTBSMWMB0, AVTBSMEF, AVTBSMEFLF

Installation Instructions & Maintenance Guide

Technical Specifications:

Supply:

Suitable for high pressure systems

Working Pressure:

1.0 bar - 5.0bar

Operating Temperature:

Hot: Max 65°C

Cold: Min 5°C

Inlet Connections:

3/4" BSP

Cartridge/Valve Type:

Thermostatic

Operation:

Separate flow and temperature control

Features:

- 38°C temperature hot stop with safety override facility
- 150mm valve centres
- 180mm bath pillar centres
- Quality chromed brass finish
- Integrated diverter to shower head
- Separate flow and temperature controls
- Easy to use long paddle handle
- AVTBSMEF & AVTBSMEFLF: Includes rail kit with adjustable handset slider, 2m hose and Satinjet water saving Kiri MK2/Kiri MK2 Low Flow handset



METHVEN
www.methven.com EST 1886

IMPORTANT: Please read all of the instructions before installation.

Specifications

- AVTBSMNK** - Pillar Mounted Thermostatic Bath Shower Mixer Only - no rail kit
- AVTBSMWMB0** - Wall Mounted Thermostatic Bath Shower Mixer Only - no rail kit
- AVTBSMEF** - Pillar Mounted Thermostatic Bath Shower Mixer complete with Easy Fit Shower Rail, 2m Hose and Satinjet Kiri MK2 Handset
- AVTBSMEFLF** - Pillar Mounted Thermostatic Bath Shower Mixer complete with Easy Fit Shower Rail, 2m Hose and Satinjet Kiri MK2 Low Flow Handset

General Characteristics

Methven recommends this product is installed by a licensed plumber in compliance with all relevant Water Authority Regulations, Water Supply (water fittings) regulations 1999. . If you are unsure as to what the regulations require, you can contact your Local Water Authority or the institute of Plumbers for further details.

This product is safe provided it is installed, used and maintained in accordance with these instructions and recommendations.

Prior to installation you should fully flush the system to ensure there is no debris in the system that could cause damage to the product

Operating Specifications

This Thermostatic Bath Shower Mixer Valve is suitable for High Pressure water heating systems provided it is installed correctly

	High Pressure
Maximum Static Pressure - Bar	10 bar
Flow Pressure, Hot & Cold - Bar	0.5 to 5
Hot Supply Temperature - °C	55°C to 65°C
Cold Supply Temperature - °C	< 25°C

NOTE: Valves operating outside these conditions cannot be guaranteed by the scheme to operate as TMV2 valves.

Operating pressure on hot and cold line should be kept as balanced as possible in order to assure maximum efficiency.

The valves designation of use is for High Pressure (HP-S & HP-T) BS EN1111
If a water supply is fed by gravity then the supply pressure should be verified to ensure the conditions of use are appropriate for the valve.

To fit the shower rail kit - If supplied

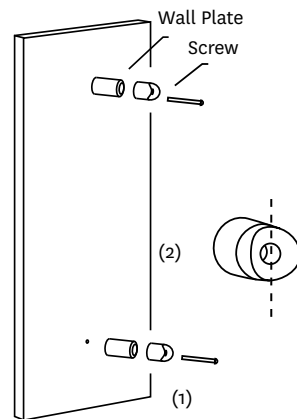

Use a 6mm drill bit to drill a hole in the wall at the desired height, drill a second hole vertically lower at a recommended height of 550mm. In certain situations, the hole may need to be further away to a maximum of 615mm. Place wall plugs into hole and push firmly into place. Place fixing bracket over the wall plugs (1) and insert screw provided, tighten until secure, repeat for second fixing bracket. Push rubber grip into fixing bracket aligning the groove vertically (2)

Assemble the handset slider, soap dish and hose retainer on to the rail ensuring button is facing upward. Attach both rail end assemblies.

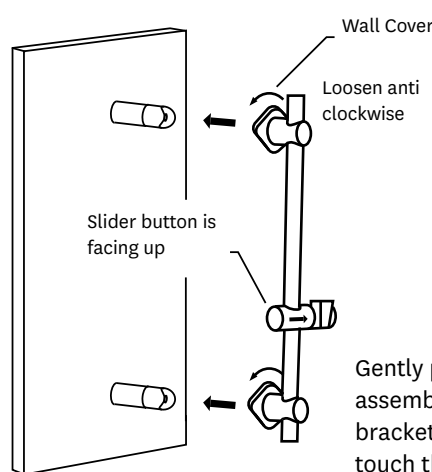
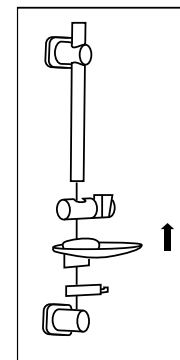

Ensuring the handset slider button is facing upwards as shown in the illustration, adjust the two rail end assemblies to match the position of the wall brackets and turn wall covers anticlockwise to the unlock position.

Gently press the rail end assemblies onto the wall brackets, until the rail ends touch the wall. Turn both wall covers clockwise into the locking position, securing the rail. Adjust handset slider to desired height for showing.

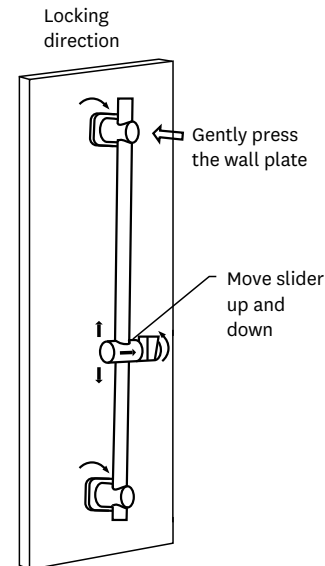

Insert flat washer into the shower hose before screwing to the handset. Connect the other end of the shower to the shower outlet.

Place the handset securely into the handset slider, and turn shower mixer into the on position and check for leaks.

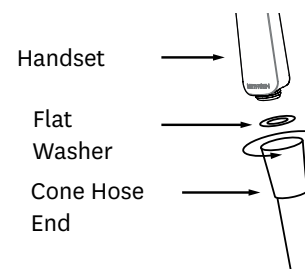

Calibration

The bath shower mixer is set at 38°C. Check this is the case by using a thermometer in the water flow from the valve.

If you require a hotter flow, re-set the calibration.

Remove the cover (1), unscrew the screw (2). The control knob (6) can now be pulled off.

Turn the spindle (A) until the temperature is at the required level.

Test again using a thermometer
Control the right position of the stepped plastic washer. When water temperature is at the required level re-fit the control knob

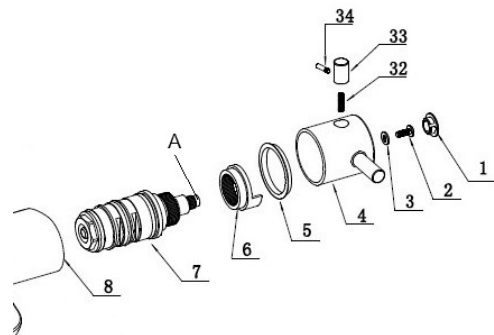

Commissioning for TMV2 Approval

Check the following:

The designation of the thermostatic mixing valve matches the application.

The supply pressures are within the valves operating range.

The supply temperatures are within the valves operating range.

Isolating valves (and strainers preferred) are provided.

If all these conditions are met, proceed to set the mixed water temperature

It is a requirement that all TMV2 approved valves shall be verified against the original set temperature results once a year. When commissioning/testing is due the following performance checks shall be carried out.

Measure the mixed water temperature at the outlet

Carry out the cold water supply isolation test by isolating the cold water supply to the TMV, wait for five seconds if water is still flowing check that the temperature is below 46°C.

If there is no significant change to the set outlet temperature ($\pm 2^\circ\text{C}$ or less change from the original settings) and the fail-safe shut off is functioning, then the valve is working correctly and no further service work is required.

If there is a residual flow during the commissioning or the annual verification (cold water supply isolation test), then this is acceptable providing the temperature of the water seeping from the valve is no more than 2°C above the designated maximum mixed water outlet temperature setting of the valve. Temperature readings should be taken at the normal flow rate after allowing for the system to stabilize.

The sensing part of the thermometer probe must be fully submerged in the water that is to be tested.

Any TMV that has been adjusted or serviced must be re-commissioned and re-tested in accordance with the manufacturers' instructions.

Line Drawing

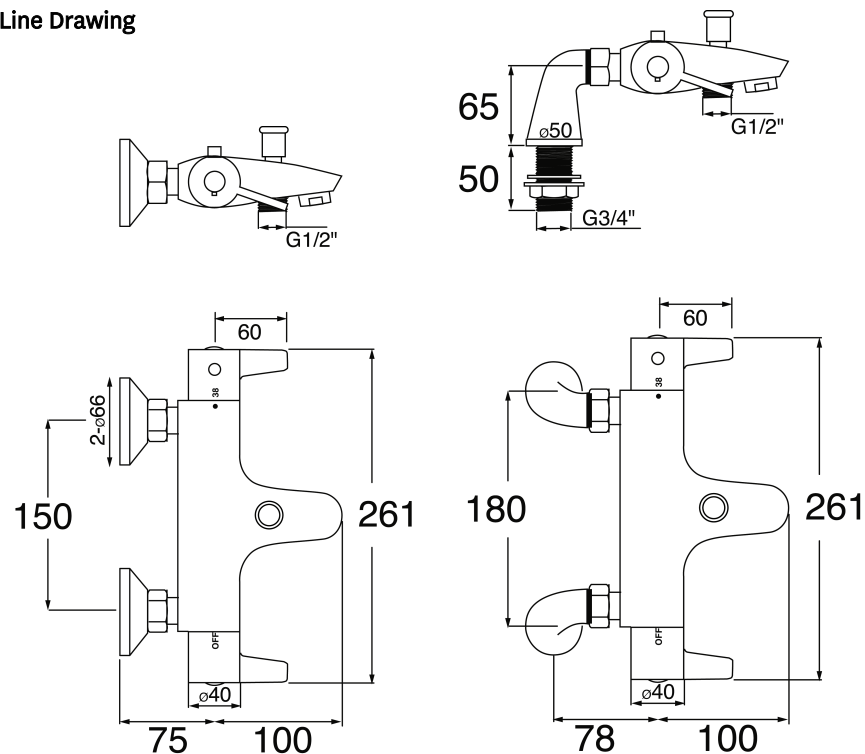

Rail kit if supplied

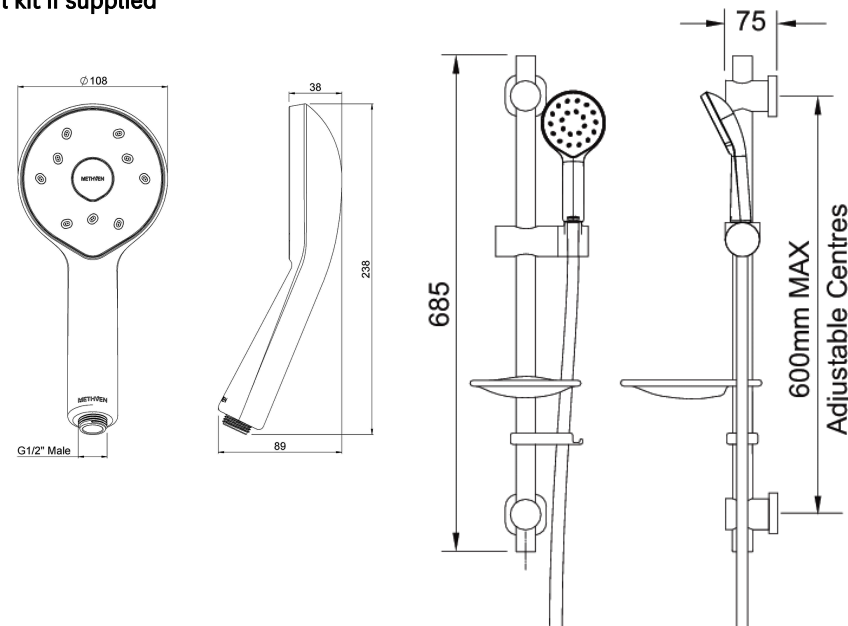

Exploded Diagram

Pillar Mounted

- | | | | |
|---|------------------------|----|--------------|
| 1 | Handle Cover | 31 | Nozzle |
| 2 | Screw | 32 | Spring |
| 3 | Washer | 33 | Button |
| 4 | Handle | 34 | Bar |
| 5 | Washer | 35 | Left Pillar |
| 6 | Washer | 36 | Washer |
| 7 | Cartridge | 37 | Backnut |
| 8 | Bath Shower Mixer Body | 38 | Right Pillar |

- | | |
|----|---------------|
| 9 | Rubber Washer |
| 10 | Divertor Cap |
| 11 | Connector |
| 12 | Cartridge |
| 13 | Handle |
| 14 | Washer |
| 15 | Nut |
| 16 | O-Ring |
| 17 | Check Valve |
| 18 | Connector |
| 19 | Filter |
| 20 | O-Ring |
| 21 | Connector |
| 22 | Allen Key |
| 23 | O-ring |
| 24 | Washer |
| 25 | Spring |
| 26 | Divertor Stem |
| 27 | O-ring |
| 28 | Connector |
| 29 | Washer |
| 30 | Aerator |

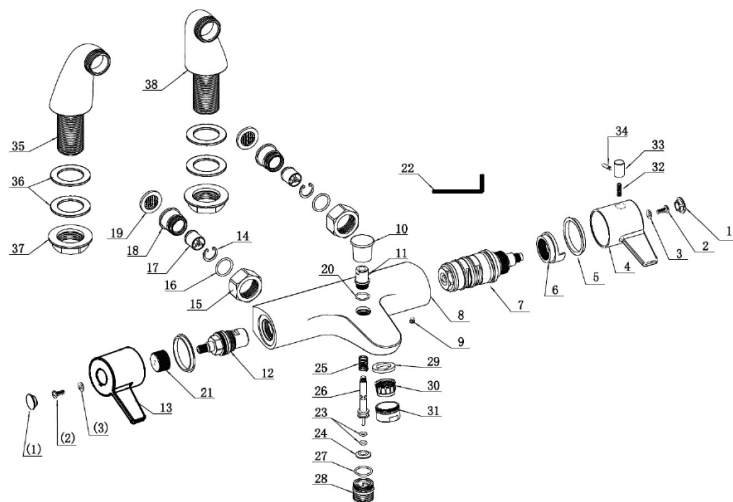

Wall Mounted

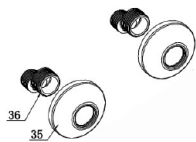

Recommended Outlet Temperature

The NSF TMV Scheme recommends the following set maximum mixed water outlet temperatures for use in all premises:

44°C for bath fill but see notes below;

41°C for showers

41°C for washbasins

38°C for bidets

The mixed water temperature must never exceed 46°C

The maximum mixed water temperature can be 2°C above the recommended maximum set outlet temperatures.

Temperature Setting

The mixer has been set in the factory under balanced pressures at 38°C. Where conditions are different from the above the temperature of the mixed water may vary from setting. You can adjust the calibration of the mixer to suit individual requirements.

Note:

46°C is the maximum mixed water temperature from the bath tap. The maximum temperature takes account of the allowable temperature tolerances inherent in thermostatic mixing valves and temperature losses in metal baths.

It is not a safe bathing temperature for adults or children.

The British Burns Association recommends 37°C to 37.5°C as a comfortable bathing temperature for children. In premises covered by the Care Standards Act 2000, the maximum mixed water outlet temperature is 43°C.

The thermostatic mixing valve will be installed in such a position that maintenance of the TMV and its valves and the commissioning and testing of the TMV can be undertaken.

The fitting of isolation valves is required as close as is practicable to the water supply inlets of the thermostatic mixing valve.

The fitting of strainers is recommended as close as is practicable to the water supply inlets of the thermostatic mixing valve.

Operating

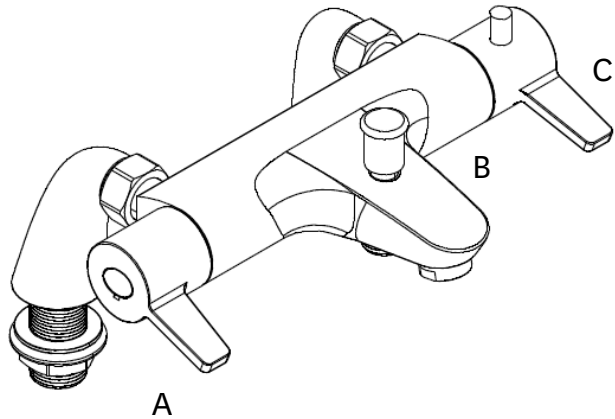

When the diverter (B) is in the lower position, water will flow through the bath filler spout. To divert water through the hose to the shower head, raise the diverter handle to be in the raised position. The diverter will remain raised until manually lowered.

Handle (A) controls the flow. Raise the handle to increase the flow of water. to either the bath filler or shower.

Handle (C) controls the temperature. Raise the handle to increase the temperature. The mixer is set to a maximum temperature of 38 degrees to prevent accidental scalding. To override to a higher temperature, press down the override button and continue to raise the handle. When the handle is lowered the safety override button will reset.

Exploded Diagram Rail kit if supplied

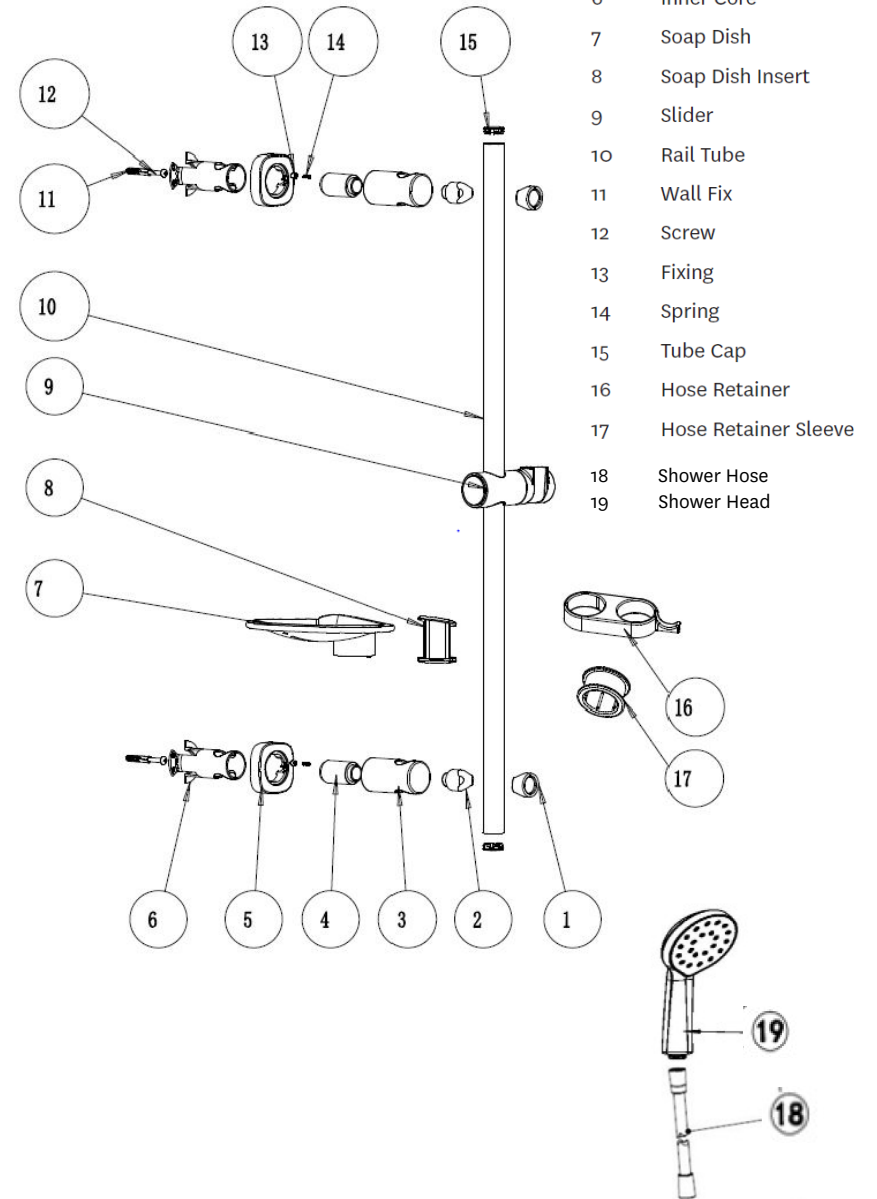

- 1 Rubber Stop
- 2 Bracket Top
- 3 Slider Housing
- 4 Inner bracket
- 5 Wall Plate
- 6 Inner Core
- 7 Soap Dish
- 8 Soap Dish Insert
- 9 Slider
- 10 Rail Tube
- 11 Wall Fix
- 12 Screw
- 13 Fixing
- 14 Spring
- 15 Tube Cap
- 16 Hose Retainer
- 17 Hose Retainer Sleeve
- 18 Shower Hose
- 19 Shower Head

Installation Instructions - Pillar Mounted (AVTBSMNK, AVTBSMEF, AVTBSMEFLF)

Important points to note before commencing installation of your bath shower mixer. You should have:-

- 1 Check the contents of the box and all parts are present and correct.
- 2 Check to ensure the minimum operating conditions can be met.
- 3 The correct tools to perform a trouble free installation
- 4 Considered the surrounding environment where the installation is to take place and any potential hidden dangers.
- 5 Isolate both the hot and cold water supplies

Assuming that the hole spacing on the bath is 180mm between centers the product can be installed onto the bath.

Install the pillars(8) onto the body(1) using the mesh filter(2) between the join.

Once the pillars are attached to the body they can be inserted through the holes on the bath, fully covering the mounting holes.

Once the pillars are inserted the back nut washer (9) can be placed over the thread followed by the back nut (10). With the whole setup loosely tightened perfect alignment can be gained. Once aligned tighten the body onto the pillars along with the back nuts (do not over tighten). Please note additional sealant can be used if required. Once the product is installed onto the bath the water outlets may be attached to the ends of the pillars. Reinststate the water supply and test for leaks.

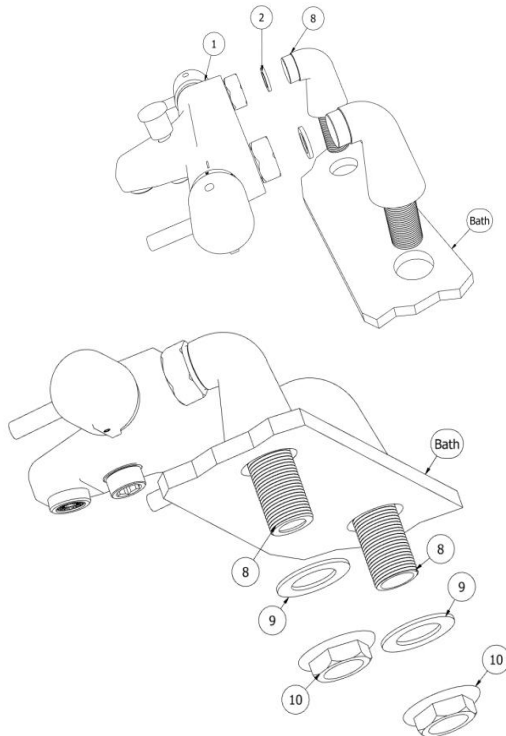

Installation Instructions - Wall Mounted Mixer (AVTBSMWMB0)

NOTE: The water outlets must be connected to the unions from behind the wall. If the water outlets are protruding through the wall an alternative union must be used.

Assuming that the water outlets are already in the wall at 150mm spacing the unions (3) can be passed through and foam washer (5), steel washer (6) and back nut (7) can be inserted and tightened as per the below diagram. The water outlets may then be connected to the unions.

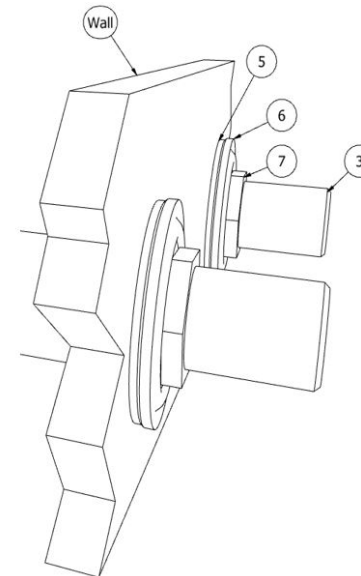

Looking at the wall from the front, the wall shrouds (4) may be screwed over the protruding unions (3) and fixed tight up to the wall.

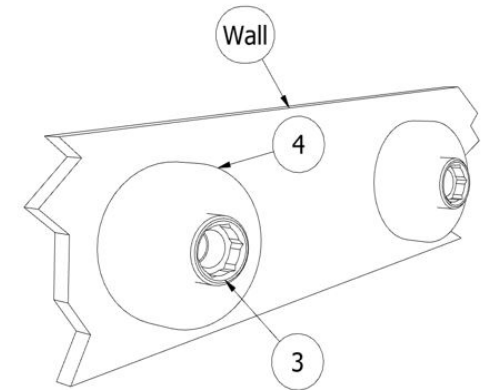

The body (1) may now be offered up to the protruding unions (3) and attached using the appropriate spanner. The mesh filter (2) must be inserted between the join.

